

TOOL MODEL NO.	TRANSDUCER ASM.	GEAR CASE ASM.	GEAR CASE HSG. COVER
AEL4A12003B	25759.001	25775	24744
AEL4A12006B	25760.002	25775	24744
AEL4A12011B	25761.003	24791	24757
AEL4A12014B	25761.005	24807	24757
AEL4A12018B	25761.008	24784	24757
AEL4A12022B	25761.010	24776	24757

COMMENTS	ITEM NO.	PART NUMBER	QTY.	DESCRIPTION
	1	25786	1	HANDLE ASSEMBLY- 1000 SERIES
	2	24780	1	MOTOR COUPLER SUB-ASM.
	3	25763	1	TRANSDUCER ADAPTOR
	4	SEE CHART	1	TRANSDUCER SUB-ASM., 20Nm
	5	25521	1	ADAPTER, PTS GEAR HOUSING
	6	SEE CHART	1	GEAR CASE ASM, P-T-S, 6T/14T
	7	25774	1	P-T-S LIGHT RING ASM
	8	SEE CHART	1	GEAR CASE HOUSING COVER, P-T-S, D.S.
	9	24753	1	P-T-S LIGHT RING LENS
	10	25590	1	O-RING, Ø13/16 X Ø1/16
	11	25591	1	O-RING, Ø1¼ X Ø1/16
	12	25897	1	WARNING LABEL, P-T-S TOOL

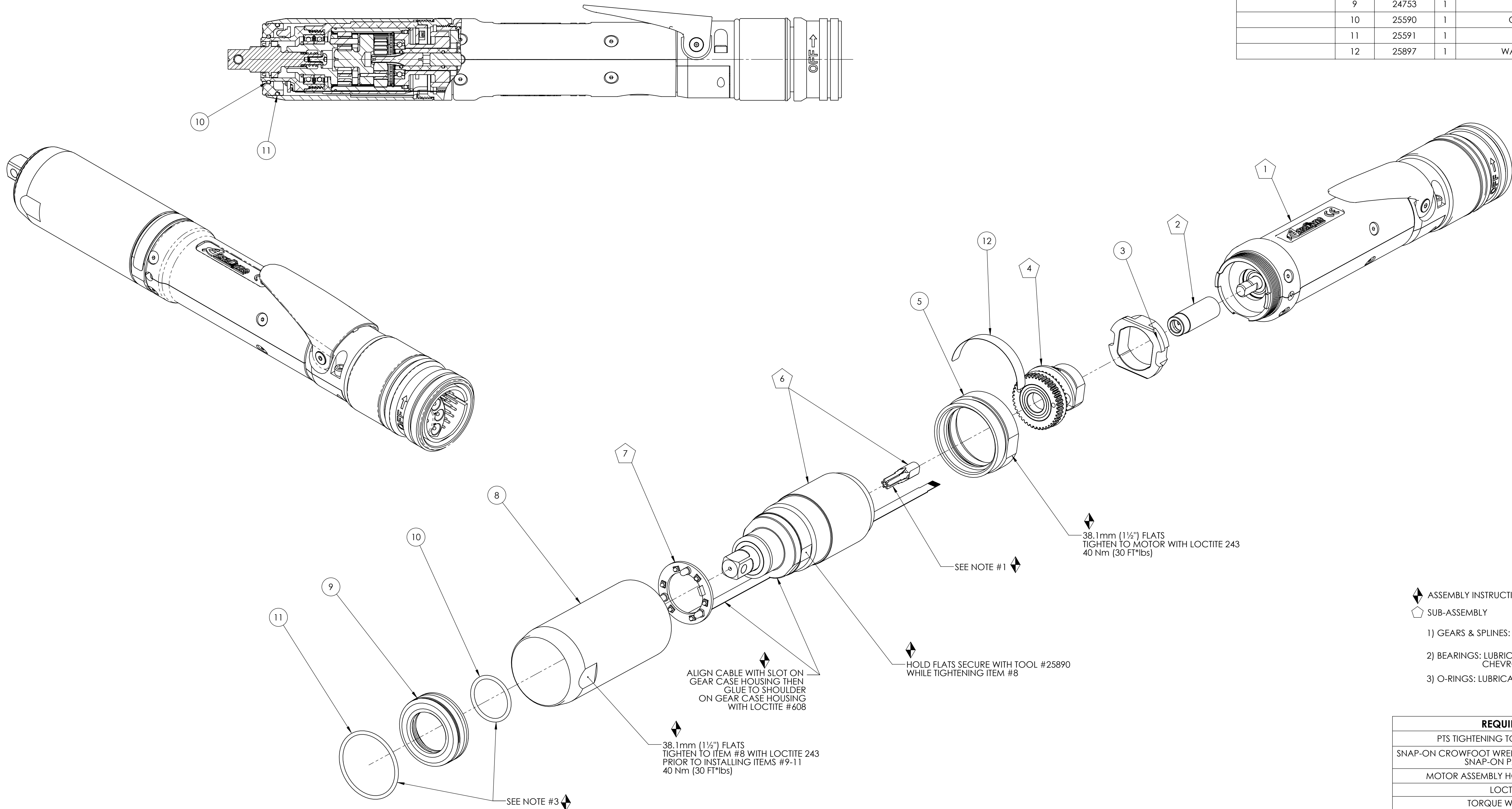

- ◆ ASSEMBLY INSTRUCTIONS
 ⬠ SUB-ASSEMBLY
- 1) GEARS & SPLINES: LUBRICATE WITH DOW CORNING MOLYKOTE BR2 PLUS GREASE.
 - 2) BEARINGS: LUBRICATE WITH CHEVRON SRT1 GREASE
 - 3) O-RINGS: LUBRICATE WITH O-RING LUBE

REQUIRED TOOLING
PTS TIGHTENING TOOL - PART NUMBER 25890
SNAP-ON CROWFOOT WRENCH, 1/2" SQ. DR. X 1-3/8" OPENING SNAP-ON PART NUMBER SC044
MOTOR ASSEMBLY HOLDER - PART NUMBER 25894
LOCTITE #243 BLUE
TORQUE WRENCH, 1/2" DRIVE
LOCTITE 608 HYSOL EPOXY ADHESIVE, HIGH STRENGTH



DOCUMENT CONTROL
 PRINTED COPIES OF THIS DOCUMENT ARE CONSIDERED TO BE UNCONTROLLED DOCUMENTS. HOLDERS ARE RESPONSIBLE FOR VERIFYING THE CURRENT REVISION LEVEL WITH PURCHASING OR ENGINEERING PRIOR TO USE OR FABRICATION. THE CONTROLLED VERSION OF THIS DOCUMENT IS ELECTRONICALLY MAINTAINED.

PROPRIETARY AND CONFIDENTIAL
 THIS DRAWING CONTAINS INFORMATION STRICTLY CONFIDENTIAL TO ACRADYNE/AIMCO. IN THE ABSENCE OF EXPRESSED WRITTEN PERMISSION, ACRADYNE/AIMCO HAS LOANED THIS COPY WITH THE MUTUAL UNDERSTANDING THAT (A) IT WILL NOT BE USED FOR ANY PURPOSE OTHER THAN FOR THAT IN WHICH IT WAS PROVIDED, (B) THE DATA CONTAINED HEREIN WILL NOT BE DISCLOSED TO OTHERS, (C) IT WILL NOT BE REPRODUCED, AND (D) IT WILL BE RETURNED TO ACRADYNE/AIMCO IMMEDIATELY UPON DEMAND.

REVISION LEVEL	REVISION RELEASE DATE	DESCRIPTION OF CHANGES MADE TO PART	ECN #	AUTHOR/ APPROVAL

UNLESS OTHERWISE SPECIFIED, DIMENSIONS ARE IN INCHES
 DIMENSIONS AND TOLERANCING PER ANSI Y14.5
 SURFACE ROUGHNESS PER ANSI Y14.36

BLOCK TOLERANCING PER DECIMAL:
 X = ±.030 XX = ±.010 XXX = ±.005 XXXX = ±.0005
 ANGLE = ±0° 30'

REMOVE BURRS AND SHARP EDGES: R.015 MAX
 MACHINE SURFACE FINISH: 125 RMS OR BETTER

DRAWINGS AND TECHNICAL DOCUMENTS CONTROLLED BY:
ACRADYNE MECHANICAL ENGINEERING

PUSH TO START NUTRUNNER
 1000 SERIES, GEN IV

SIZE	PART / DRAWING NUMBER	REVISION
D	AEL4A12__B	B

SCALE: 1:1 DO NOT SCALE DRAWING SHEET 1 OF 2

**REACTION DEVICE
MOUNTING DIMENSIONS**

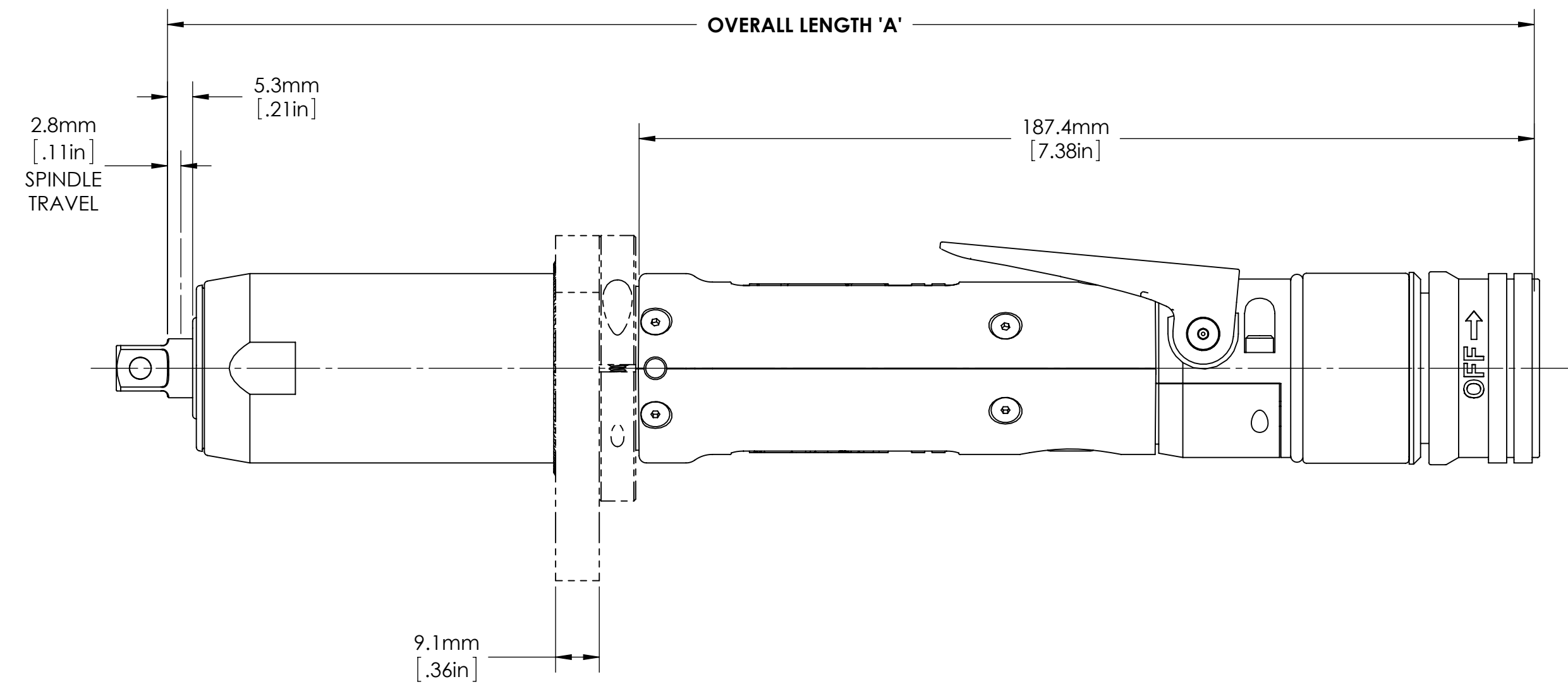
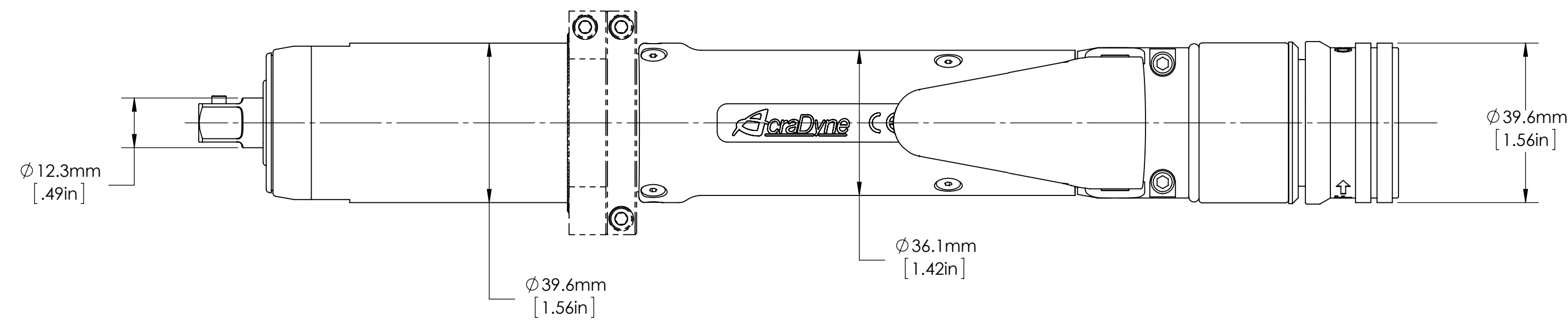
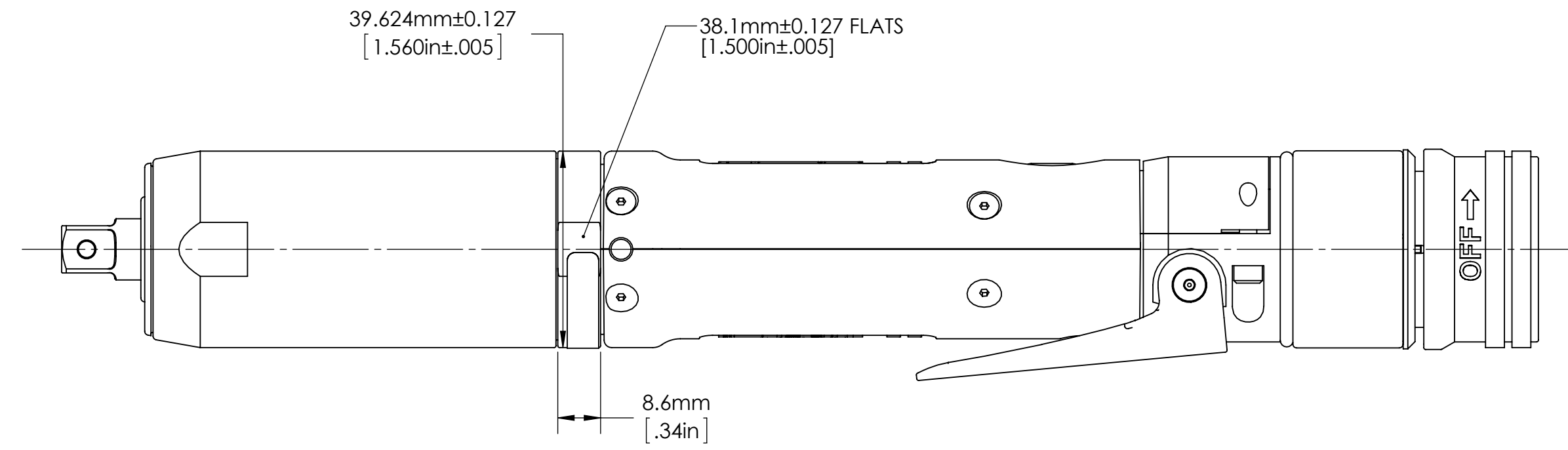

TOOL MODEL NO.	OVERALL LENGTH 'A'
AEL4A12003B	271.6mm [10.69in]
AEL4A12006B	271.6mm [10.69in]
AEL4A12011B	286.1mm [11.26in]
AEL4A12014B	286.1mm [11.26in]
AEL4A12018B	286.1mm [11.26in]
AEL4A12022B	286.1mm [11.26in]

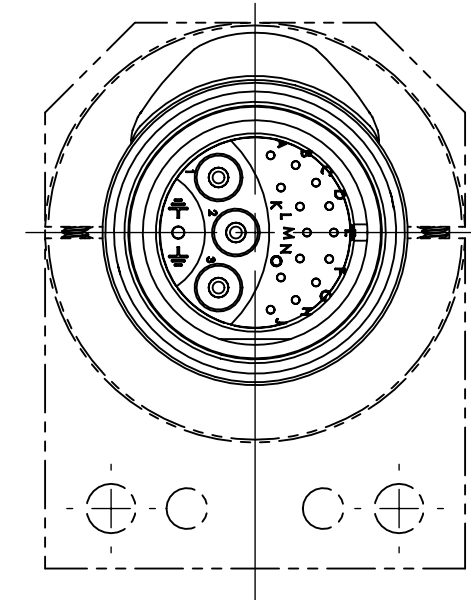
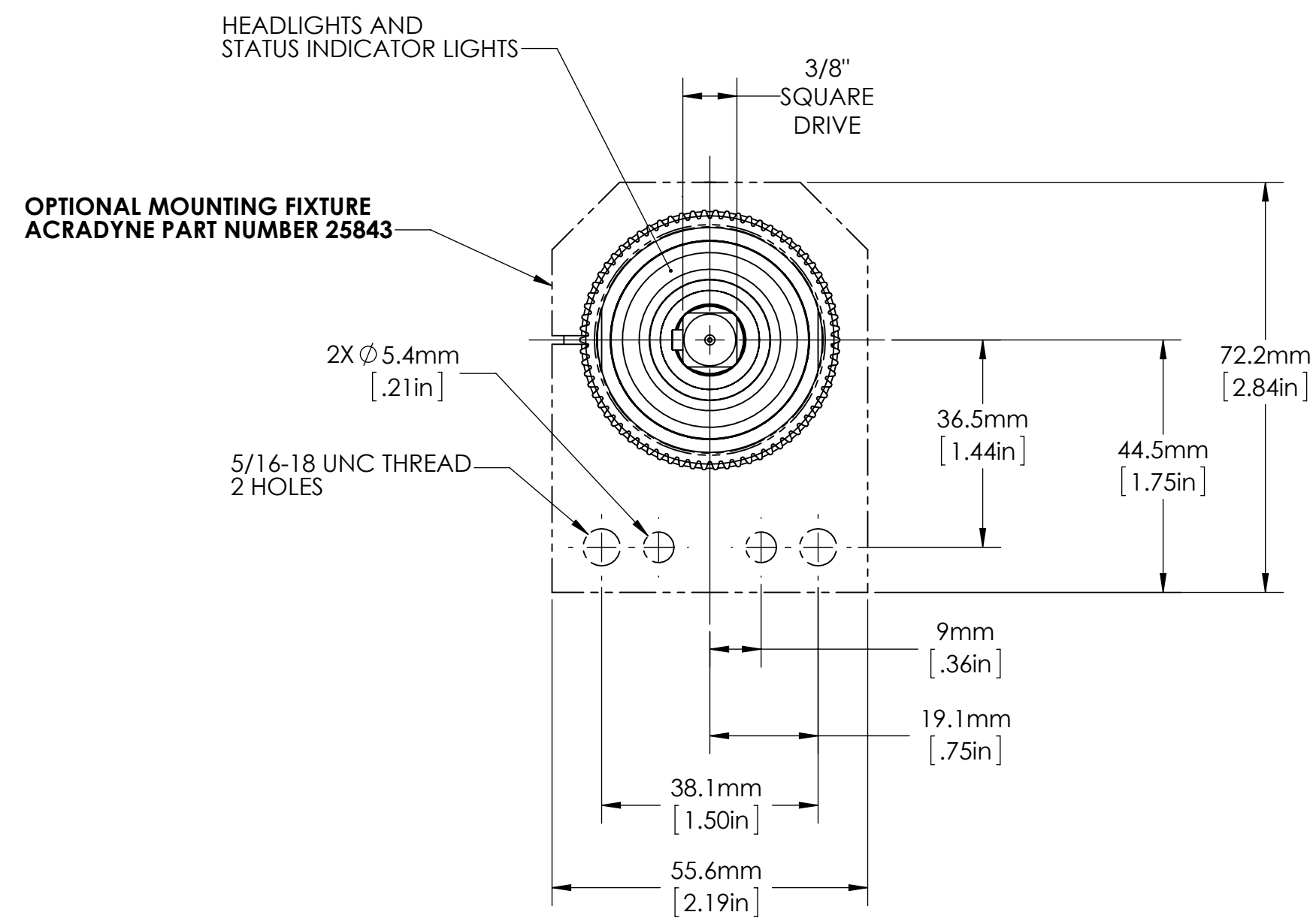

DOCUMENT CONTROL
PRINTED COPIES OF THIS DOCUMENT ARE CONSIDERED TO BE UNCONTROLLED DOCUMENTS. HOLDERS ARE RESPONSIBLE FOR VERIFYING THE CURRENT REVISION LEVEL WITH PURCHASING OR ENGINEERING PRIOR TO USE OR FABRICATION. THE CONTROLLED VERSION OF THIS DOCUMENT IS ELECTRONICALLY MAINTAINED.

PROPRIETARY AND CONFIDENTIAL
THIS DRAWING CONTAINS INFORMATION STRICTLY CONFIDENTIAL TO ACRADYNE/AIMCO. IN THE ABSENCE OF EXPRESSED WRITTEN PERMISSION, ACRADYNE/AIMCO HAS LOANED THIS COPY WITH THE MUTUAL UNDERSTANDING THAT (A) IT WILL NOT BE USED FOR ANY PURPOSE OTHER THAN FOR THAT IN WHICH IT WAS PROVIDED, (B) THE DATA CONTAINED HEREIN WILL NOT BE DISCLOSED TO OTHERS, (C) IT WILL NOT BE REPRODUCED, AND (D) IT WILL BE RETURNED TO ACRADYNE/AIMCO IMMEDIATELY UPON DEMAND.

REVISION LEVEL	REVISION RELEASE DATE	DESCRIPTION OF CHANGES MADE TO PART	ECN #	AUTHOR/ APPROVAL

UNLESS OTHERWISE SPECIFIED, DIMENSIONS ARE IN INCHES
DIMENSIONS AND TOLERANCING PER ANSI Y14.5
SURFACE ROUGHNESS PER ANSI Y14.36

BLOCK TOLERANCING PER DECIMAL:
X = ±.030 XX = ±.010 XXX = ±.005 XXXX = ±.0005
ANGLE = ±0° 30'

REMOVE BURRS AND SHARP EDGES: R.015 MAX
MACHINE SURFACE FINISH: 125 RMS OR BETTER

DRAWINGS AND TECHNICAL DOCUMENTS CONTROLLED BY:
ACRADYNE MECHANICAL ENGINEERING

**PUSH TO START NUTRUNNER
1000 SERIES, GEN IV**

SIZE D	PART / DRAWING NUMBER AEL4A12__B	REVISION B
SCALE 1:1	DO NOT SCALE DRAWING	SHEET 2 OF 2